



Maintenance-Free Rechargeable Sealed Lead-Acid Battery

BP8-12



The battery is constructed by plates, separators, safety valves and container. Since the electrolyte is held by a glass-mat separator and plates, the battery can use in any direction and position without leakage.

PERFORMANCE SPECIFICATIONS

Nominal Voltage(V).....	12 volts(6cells in series)
Nominal Capacity(AH)	
20 hour rate F.V.(1.75 V/cell) (400mA to 10.50volts)	8.0A.H.
10 hour rate F.V.(1.75 V/cell) (760mA to 10.50volts).....	7.60A.H.
5 hour rate F.V.(1.75V/cell) (1360mA to 10.50volts).....	6.80A.H.
1 hour rate F.V.(1.55V/cell) (4800mA to 9.30volts).....	4.80A.H.
Approximate Weight.....	2650g(5.84lbs.)
Terminal	
Standard.....	Type T2
Optional.....	Type T1
Internal Resistance (Fully Charged Battery).....	<25m Ω
Maximum Discharge Current For 5 sec.(A).....	120A
Maximum Charge Current(A).....	2.40A
Ambient Temperature	
Charge.....	0°C(32°F)~40°C(104°F)
Discharge.....	-20°C(-4°F)~50°C(122°F)
Storage.....	-20°C(-4°F)~40°C(104°F)
Vibration test:	
Frequency: 16.7HZ	
Amplitude: 4mm	
Vibrate the battery horizontally or vertically for 60 minutes.The battery have no abnormality.	
Case.....	ABS
Dimension(mm/inch)	
Length ±1.5mm.....	151/5.94
Width ±1.5mm.....	65/2.56
Container Height ±1.5mm.....	94/3.70
Total Height ±2mm.....	100/3.94
Application.....	UPS, Laboratory Equipment.

BP8-12 Battery discharge characteristics (25 °C/77 °F)

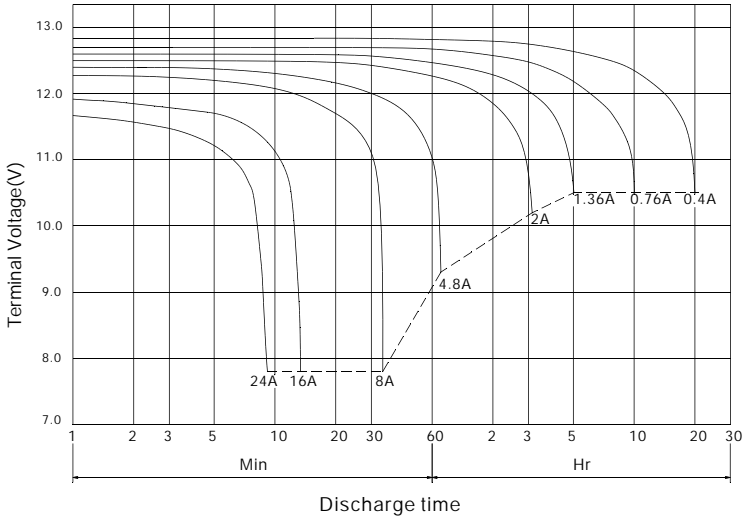

BATTERY CHARGING CHARACTERISTICS

(Typical example of the charge characteristics for the standby use)

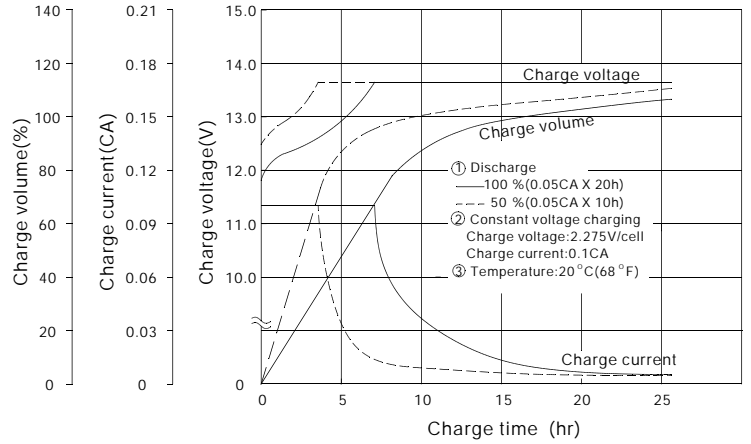

Charging Procedure

Application	Charging method	Charging Voltage at 20°C (V/cell)	Temperature compensation coefficient of charging voltage (mV/C /cell)	Max. charging current (CA)	Charging time 0.1CA, 20°C (h)		Temp (°C)
					100% discharge	50% discharge	
For standby power Source	Constant voltage & Constant current charging (with current restriction)	2.25-2.30	-3	0.3	24	20	0~40 (32-104°F)
For cycle service		2.40-2.50	-4	0.3	16	10	

*Temperature compensation of charging voltage is not needed, when using the batteries within 5 °C to 35 °C range.

Effect of Temperature on Long Term Float Life

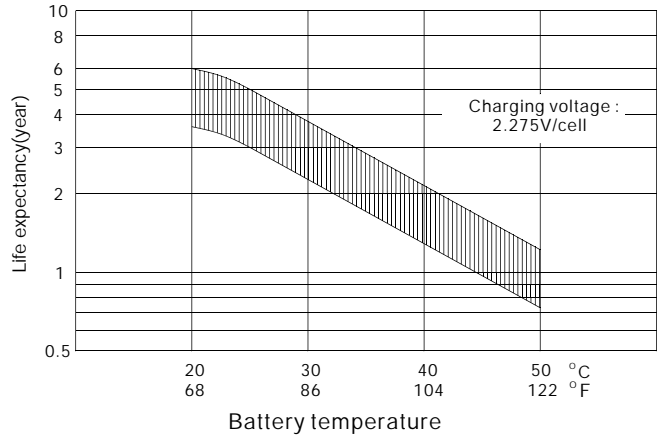

TERMINAL TYPE

mm (inch)

OUTER DIMENSIONS

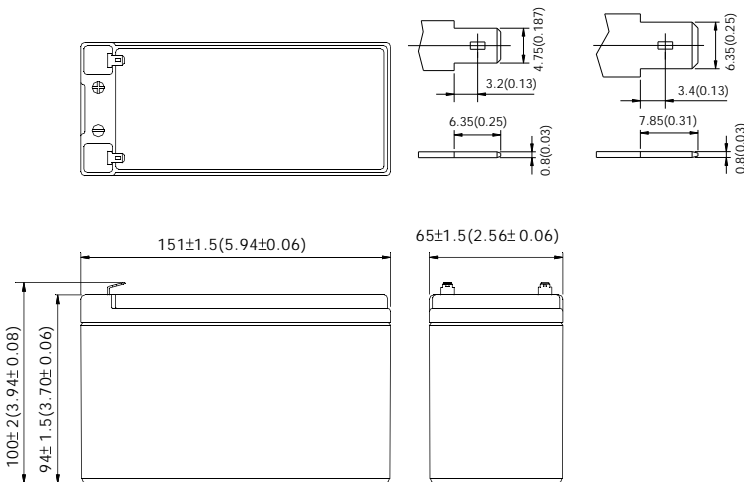

Constant power discharge characteristics at 25 °C/77 °F

Final Voltage	Discharge time								
	5Min	10Min	15Min	30Min	1Hr	3Hr	5Hr	10Hr	20Hr
	Battery output power (W)								
10.80V	289.2	212.9	170.6	101.5	58.22	23.32	16.08	8.99	4.70
10.50V	334.8	230.7	178.5	105.4	59.97	23.79	16.32	9.12	4.80
10.20V	355.7	239.0	184.0	107.8	61.05	24.00	16.41	9.17	4.82
9.90V	371.7	244.7	188.2	109.3	61.78	24.17	16.47	9.19	4.83
9.60V	384.0	249.6	192.0	110.4	62.40	24.31	16.52	9.19	4.83

TERMINAL POSITION

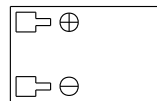

B.B. BATTERY CO., LTD. Web Site: <http://www.bb-battery.com>

USA :

B&B BATTERY (USA) INC.
6415 RANDOLPH ST. COMMERCE,
CA, 90040 U.S.A.
TEL: 1-323-278-1900 1-800-278-8599
FAX: 1-323-278-1268

CHINA FACTORY:

CHENG DONG TRIAL AREA, HUANG GANG,
RAOPING GUANG DONG, CHINA, 515700
TEL: 86-768-7601001-2
FAX: 86-768-7601469

UK:

B & B BATTERY (UK) CO., LTD.
TEL: 44-161-339-9458
FAX: 44-161-343-7030

HONG KONG:

NATIONAL TRADING LTD.
TEL: 852-2301-3800
FAX: 852-2739-1182

JAPAN:

B & B BATTERY (JAPAN) CO., LTD.
TEL: 81-426-256-537
FAX: 81-426-256-537

TAIWAN:

B & B BATTERY CO., LTD.
TEL: 886-6-5898081-3
FAX: 886-6-5898087



MH19884

