



Maintenance-Free Rechargeable Sealed Lead-Acid Battery



BP13-6(H)

The battery is constructed by plates, separators, safety valves and container. Since the electrolyte is held by a glass-mat separator and plates, the battery can use in any direction and position without leakage.

PERFORMANCE SPECIFICATIONS

Nominal Voltage(V).....	6 volts(3cells in series)
Nominal Capacity(AH)	
20 hour rate F.V.(1.75V/cell) (650mA to 5.25volts)	13.0A.H.
10 hour rate F.V.(1.75V/cell) (1235mA to 5.25volts).....	12.35A.H.
5 hour rate F.V.(1.75V/cell) (2210mA to 5.25volts)	11.05A.H.
30 Min rate F.V.(1.30V/cell) (13000mA to 3.90volts).....	6.50A.H.
Approximate Weight.....	2500g(5.51lbs.)
Terminal	
Standard.....	Type H
Fuse.....	Type 30A
Internal Resistance (Fully Charged Battery).....	<8m Ω
Maximum Discharge Current For 5 sec.(A).....	30A
Maximum Charge Current(A).....	3.90A
Ambient Temperature	
Charge.....	0°C(32°F)~40°C(104°F)
Discharge.....	-20°C(-4°F)~50°C(122°F)
Storage.....	-20°C(-4°F)~40°C(104°F)
Vibration test:	
Frequency: 16.7HZ	
Amplitude: 4mm	
Vibrate the battery horizontally or vertically for 60 minutes. The battery have no abnormality.	
Case.....	ABS
Dimension(mm/inch)	
Length ±1.5mm.....	108/4.25
Width ±1.5mm.....	71/2.80
Container Height ±1.5mm.....	140/5.51
Application.....	Electronic Toy-Cars, Emergency Lights, Rechargeable Flash Lights, Fans.

BP13-6(H) Battery discharge characteristics (25 °C/77 °F)

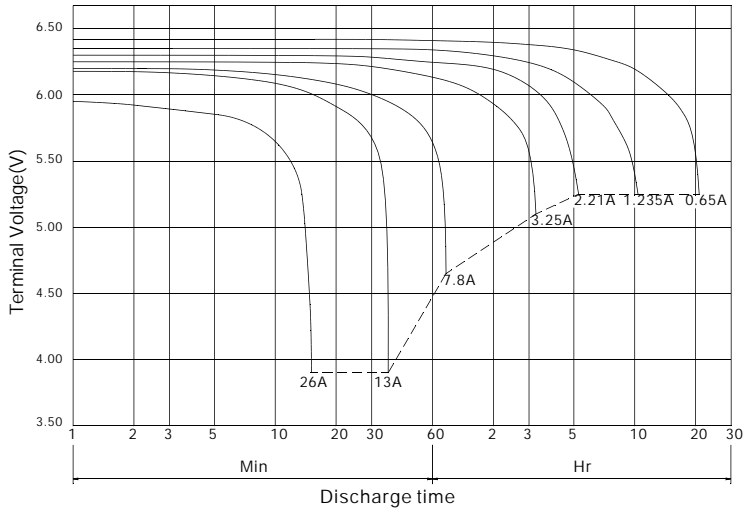

BATTERY CHARGING CHARACTERISTICS

(Typical example of the charge characteristics for the cycle use)

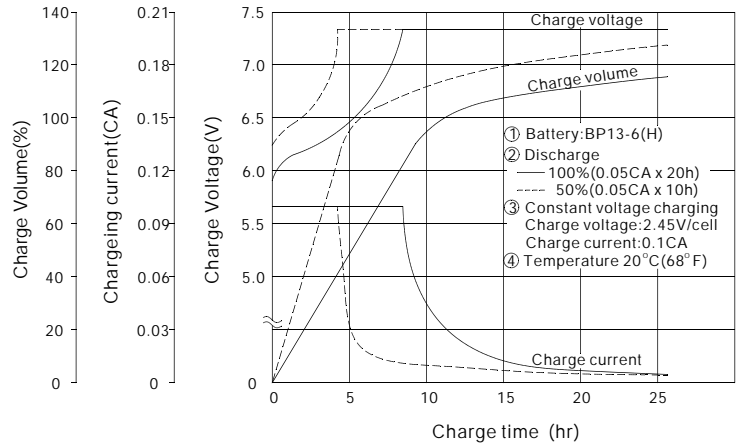

Charging Procedure

Application	Charging method	Charging Voltage at 20°C (V/cell)	Temperature compensation coefficient of charging voltage (mV/°C/cell)	Max. charging current (CA)	Charging time 0.1CA, 20°C (h)		Temp (°C)
					100% discharge	50% discharge	
For standby power source	Constant voltage & Constant current charging (with current restriction)	2.25~2.30	-3	0.3	24	20	0~40 (32~104°F)
For cycle service	Constant voltage & Constant current charging (with current restriction)	2.40~2.50	-4	0.3	16	10	

*Temperature compensation of charging voltage is not needed, when using the batteries within 5°C to 35°C range.

Battery Life Characteristics of Cyclic Use

Testing Conditions : Discharge Current : 0.25C Amp (F.V. 1.7V/cell)
 Charging Current : 0.1C Amp
 Charging Volume : 120% OF Discharge Capacity
 Ambient Temperature : 20C (68F)

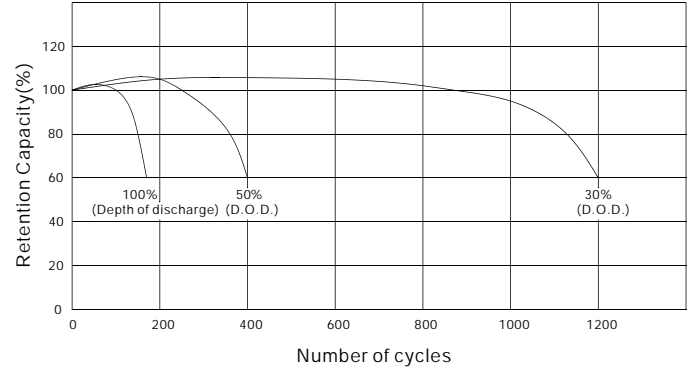

OUTER DIMENSIONS mm(inch)

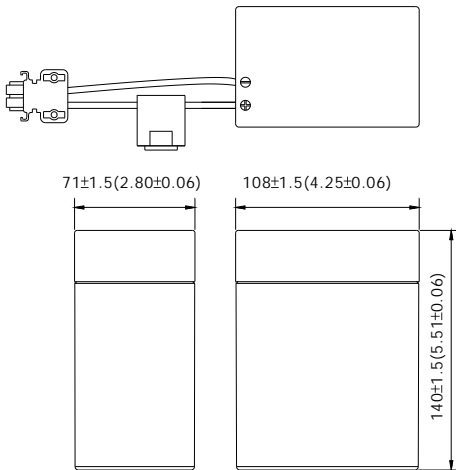

TERMINAL TYPE

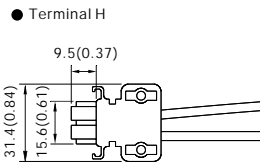

TERMINAL POSITION

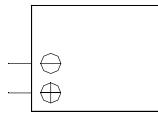

Constant power discharge characteristics at 25°C/77°F

Final Voltage	Discharge time					
	30Min	1Hr	3Hr	5Hr	10Hr	20Hr
5.40V	82.5	47.31	18.95	13.06	7.30	3.82
5.25V	85.6	48.73	19.33	13.26	7.41	3.90
5.10V	87.6	49.60	19.50	13.33	7.45	3.92
4.95V	88.8	50.20	19.64	13.38	7.47	3.93
4.80V	89.7	50.70	19.75	13.42	7.47	3.93



B.B. BATTERY CO., LTD. Web Site: <http://www.bb-battery.com>

USA :

B&B BATTERY (USA) INC.
 6415 RANDOLPH ST. COMMERCE,
 CA, 90040 U.S.A.
 TEL: 1-323-278-1900 . 1-800-278-8599
 FAX: 1-323-278-1268

CHINA FACTORY:

CHENG DONG TRIAL AREA, HUANG GANG,
 RAOPING GUANG DONG, CHINA, 515700
 TEL: 86-768-7601001-2
 FAX: 86-768-7601469

UK:

B & B BATTERY (UK) CO., LTD.
 TEL: 44-161-339-9458
 FAX: 44-161-343-7030

HONG KONG:

NATIONAL TRADING LTD.
 TEL: 852-2301-3800
 FAX: 852-2739-1182

JAPAN:

B & B BATTERY (JAPAN) CO., LTD.
 TEL: 81-426-256-537
 FAX: 81-426-256-537

TAIWAN:

B & B BATTERY CO., LTD.
 TEL: 886-6-5898081-3
 FAX: 886-6-5898087



MH19884

