



# Valve Regulated Lead-Acid Rechargeable Battery



## EB12-12

The battery is constructed by plates, separators, safety valves and container. Since the electrolyte is held by a glass-mat separator and plates, the battery can be used in any direction and position without leakage.

### PERFORMANCE SPECIFICATIONS

Nominal Voltage(V).....	12 volts(6cells in series)
Nominal Capacity(AH)	
20 hour rate F.V.(1.75V/cell) (0.6A to 10.50volts) .....	12.0A.H.
2 hour rate F.V.(1.60V/cell) (5.0A to 9.60volts) .....	10.0A.H.
Approximate Weight.....	4300g(9.48lbs.)
Terminal	
Standard.....	Type T2
Internal Resistance (Fully Charged Battery).....	<12mΩ
Maximum Discharge Current For 5 sec.(A).....	180A
Maximum Charge Current(A).....	3.6A
Ambient Temperature	
Charge.....	0°C(32°F)~40°C(104°F)
Discharge.....	-20°C(-4°F)~50°C(122°F)
Storage.....	-20°C(-4°F)~40°C(104°F)
Vibration test:	
Frequency: 16.7HZ	
Amplitude: 4mm	
Vibrate the battery horizontally or vertically for 60 minutes. The battery have no abnormality.	
Case.....	ABS
Dimension(mm/inch)	
Length           ±1.5mm.....	151/5.94
Width           ±1.5mm.....	98/3.86
Container Height ±1.5mm.....	94/3.70
Total Height   ±1.5mm.....	98/3.86
Application.....	E-bike, Wheelchairs, Lawn Mowers, Electrical Scooter, Golf-Carts.
Cycle Life.....	Approx. 300 Cycles(D.O.D.100%), 500 Cycles(D.O.D.70%)

## EB12-12 Battery discharge characteristics (25°C/77°F)

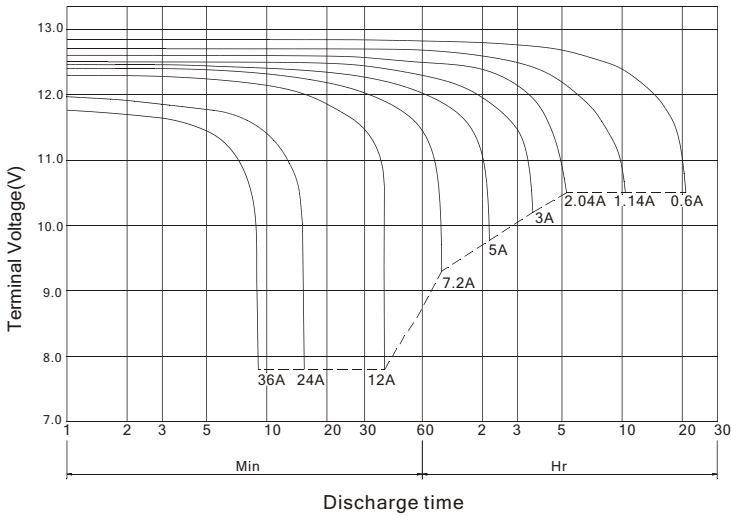

## Battery Charging Characteristics

(Typical example of the charge characteristics for the standby use)

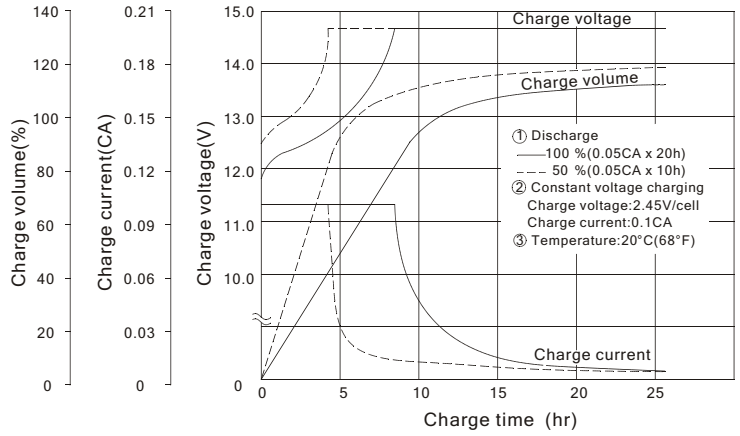

## Battery Life Characteristics of Cyclic Use

Testing Conditions : Discharge Current : 5Amp  
Final voltage: 1.60V/cell  
Charging Current : 0.1C Amp  
Charging Volume : 120% of Discharge Capacity  
Ambient Temperature : 20 °C (68 °F)

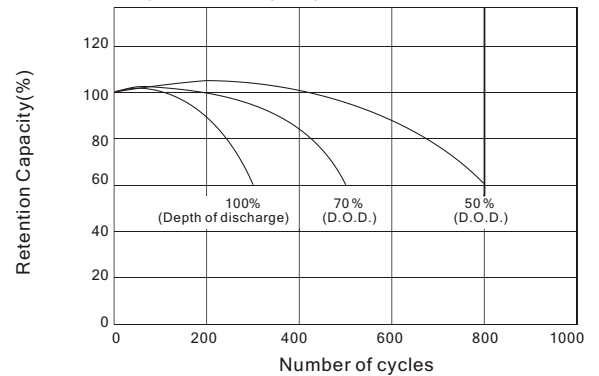

## Charging Procedure

Application	Charging method	Charging Voltage at 20°C (V/cell)	Temperature compensation coefficient of charging voltage (mV/°C/cell)	Max. charging current (CA)	Charging time 0.1CA, 20°C (h)		Temp (°C)
					100% discharge	50% discharge	
For standby power Source	Constant voltage & Constant current charging (with current restriction)	2.25~2.30	-3	0.3	24	20	0~40 (32~104°F)
For cycle service		2.40~2.50	-4	0.3	16	10	

\*Temperature compensation of charging voltage is not needed, when using the batteries within 5°C to 35°C range.

## OUTER DIMENSIONS

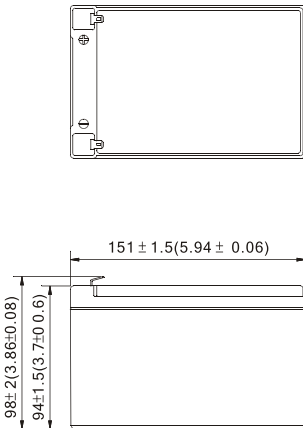

## TERMINAL TYPE

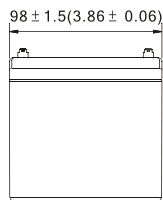
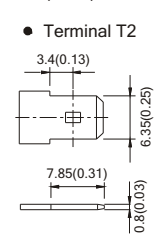

## Constant power discharge characteristics at 25°C/77°F

Final Voltage	Discharge time									
	10Min	15Min	30Min	40Min	1Hr	2Hr	3Hr	5Hr	10Hr	20Hr
10.80V	323.2	261.7	164.6	130.5	99.6	56.8	42.0	26.6	13.47	7.05
10.50V	350.2	274.0	170.9	135.2	102.5	58.2	42.8	27.0	13.68	7.20
10.20V	362.8	282.3	174.7	138.0	104.3	58.9	43.2	27.2	13.75	7.23
9.90V	371.5	288.9	177.2	139.9	105.7	59.8	43.6	27.4	13.78	7.25
9.60V	378.8	294.6	179.0	141.3	106.8	60.0	43.8	27.4	13.78	7.25
9.00V	386.4	300.5	180.0	142.7	107.9	60.6	44.1	27.4	13.78	7.25

## Constant current discharge characteristics at 25°C/77°F

Final Voltage	Discharge time									
	10Min	15Min	30Min	40Min	1Hr	2Hr	3Hr	5Hr	10Hr	20Hr
10.80V	28.4	22.8	13.9	11.0	8.4	4.73	3.50	2.22	1.123	0.588
10.50V	30.8	23.8	14.5	11.4	8.6	4.85	3.58	2.25	1.140	0.600
10.20V	31.9	24.6	14.8	11.6	8.8	4.91	3.60	2.26	1.145	0.602
9.90V	32.7	25.1	15.0	11.8	8.9	4.98	3.62	2.28	1.150	0.605
9.60V	33.4	25.6	15.2	11.9	9.0	5.00	3.65	2.28	1.150	0.605
9.00V	34.0	26.1	15.3	12.0	9.1	5.05	3.67	2.28	1.150	0.605



**B.B. BATTERY CO., LTD.**

Web Site: <http://www.bb-battery.com>

**USA:**  
B&B BATTERY(USA) INC.  
6415 RANDOLPH ST.COMMERCE,  
CA,90040 U.S.A.  
TEL:1-323-278-1900-1-800-278-8599  
FAX:1-323-278-1268  
E-Mail:sales@bb-battery.com

**EUROPE:**  
B&B BATTERY(EUROPE) B.V.  
3 WIJNGAARDVELD, 9300 AALST,BELGIUM  
TEL:(00)32-53781567  
FAX:(00)32-53781567  
E-Mail:hansdevriese@bb-battery.com

**CHINA FACTORY:**  
B.B. BATTERY CO., LTD.  
CHENG DONG TRIAL AREA,HUANG GANG,  
RAOPING, GUANG DONG,CHINA,515700  
TEL:86-768-7601001-2  
FAX:86-768-7601469  
E-Mail:maggy@bb-battery.com

**HONG KONG:**  
NATIONAL TRADING LTD.  
TEL:852-2301-3800  
FAX:852-2739-1182  
E-Mail:bbhk@hkstar.com

**JAPAN:**  
B&B BATTERY(JAPAN) CO., LTD.  
1375-11 NARAHARA-MACHI, HACHIOJI,  
TOKYO 193-0803,JAPAN.  
TEL:81-426-25-6375  
FAX:81-426-25-6375  
E-Mail:miyata@bb-battery.com

**TAIWAN:**  
B.B. BATTERY(TAIWAN) CO., LTD.  
TEL:886-6-502-5150  
FAX:886-6-589-8087  
E-Mail:maggy@bb-battery.com

